

Heat pump TCLM Komplet Diagram of cooling circuit wiring - heating

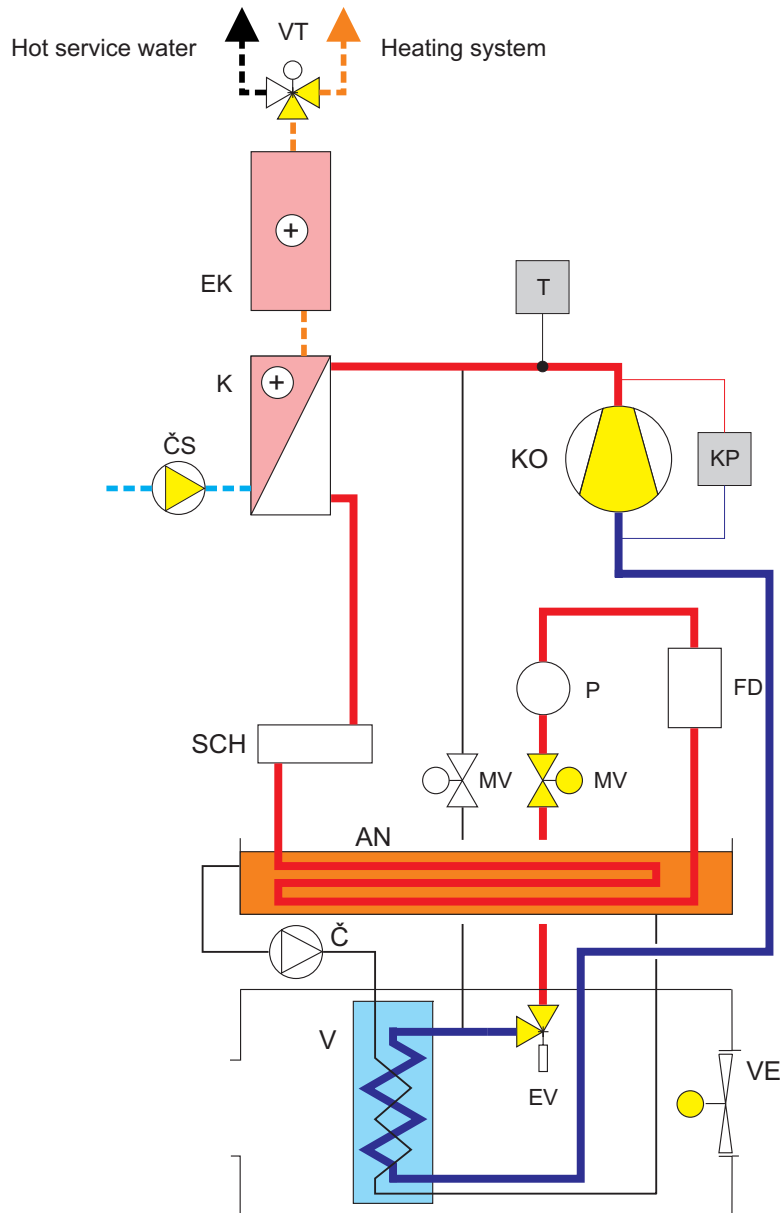

Glossary:

AN	-	accumulation tank	KP	-	pressostat
Č	-	pump - defrosting circuit	MV	-	solenoid valve
ČS	-	pump - secondary circuit	P	-	liquid indicators
EK	-	electro-boiler	SCH	-	receiver
EV	-	expansion valve	T	-	thermostat
FD	-	filter drier	V	-	evaporator
K	-	condenser	VE	-	fan - primary circuit
KO	-	compressor	VT	-	three-way valve

Dimensional sketches of TCLM Komplet 5.3 (7.1) heat pumps

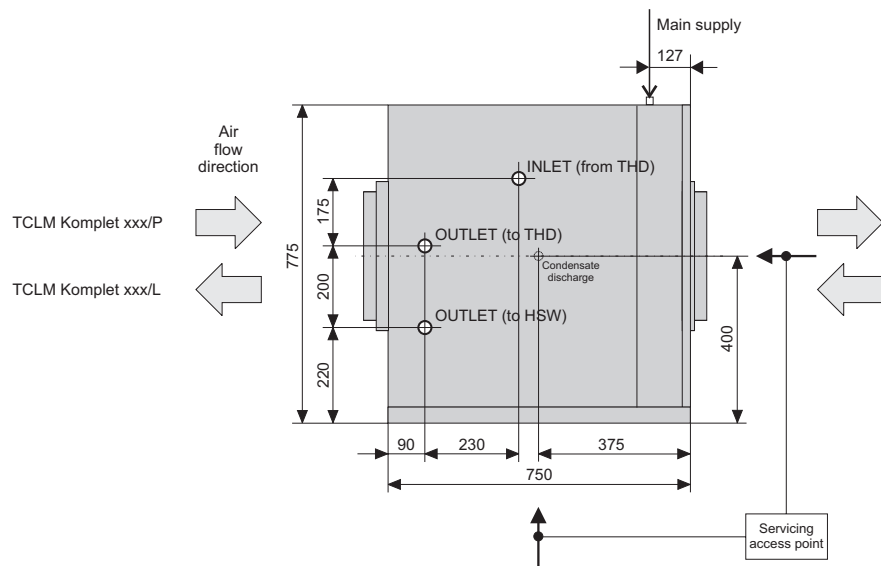
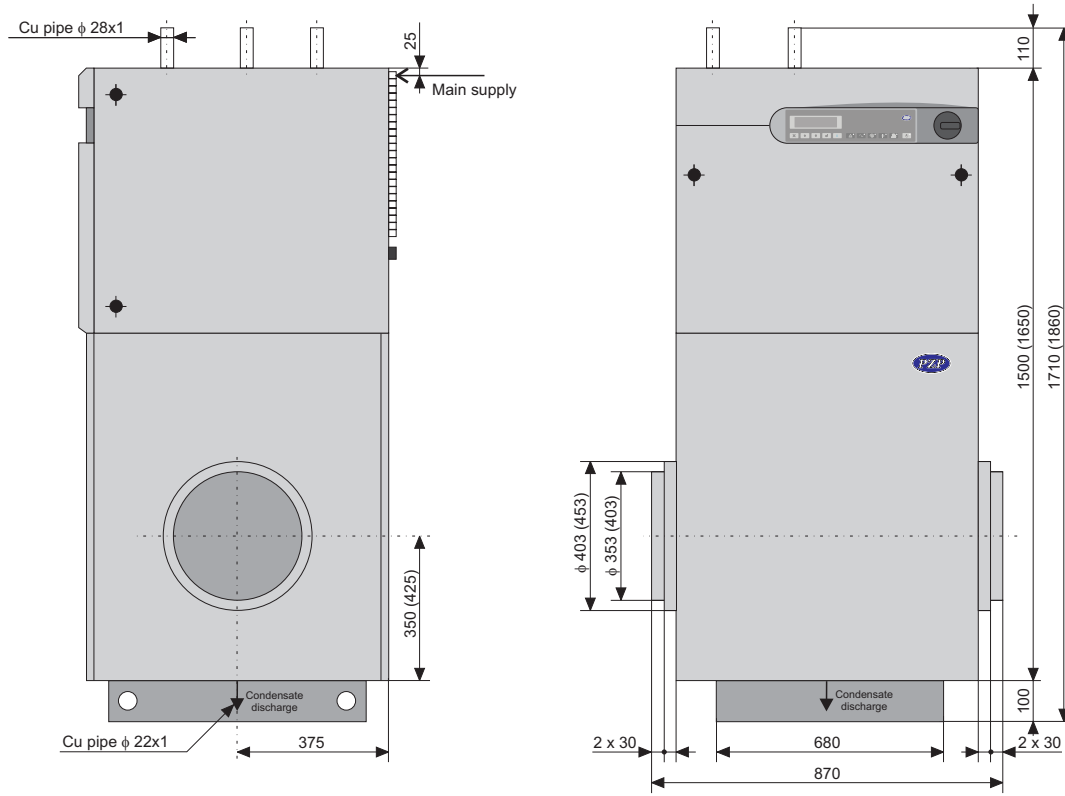

Bushing with grill

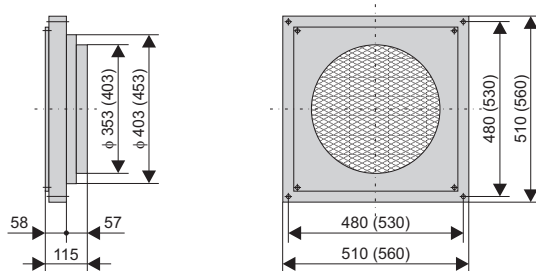

Detailed mounting

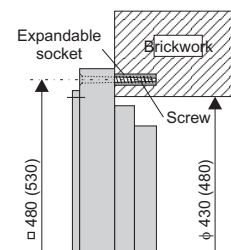

Principle of the connection of TCLM Komplet heat pumps

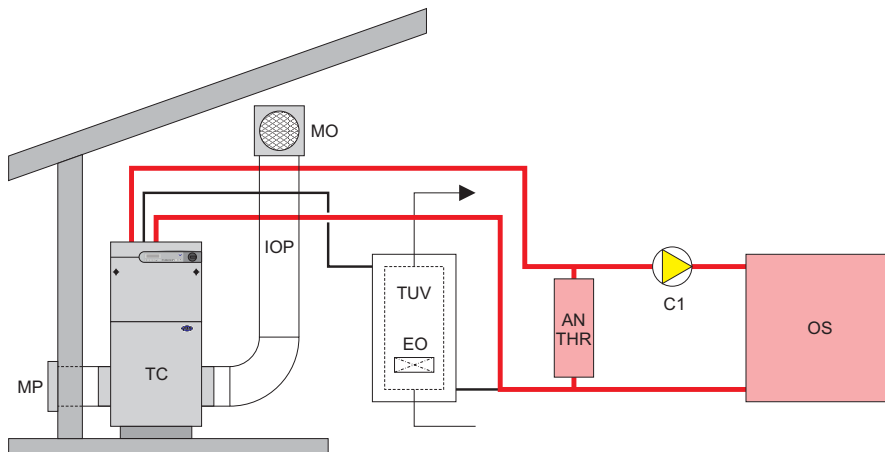

Picture 1a HSW preheating in a double-wall boiler during a heating delay period. The 'heating' working mode.

Explanation:

- AN - Accumulation tank
- C1 - Circular pump for heating system
- EO - Electrical heating
- IOP - Insulated flexible piping
- MO - Air removal grill
- MP - Air supply grill
- OS - Heating system
- TC - TCLM Komplet heat pump
- THR - Thermohydraulic distributor (THD)
- TUV - Hot service water

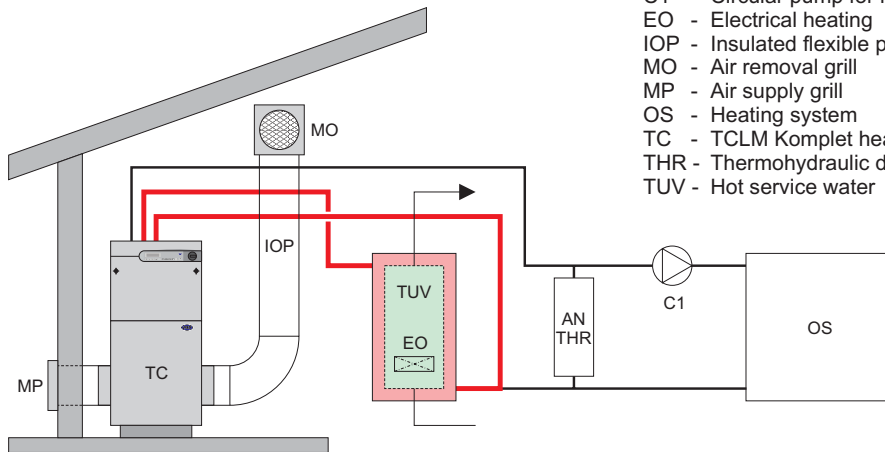

Picture 1b HSW preheating in a double-wall boiler during a heating delay period. The 'HSW preheating' working mode.

Explanation:

- C2 - Circular pump for KZ
- KZ - Standard (existing) source
- SVS - Existing heating system

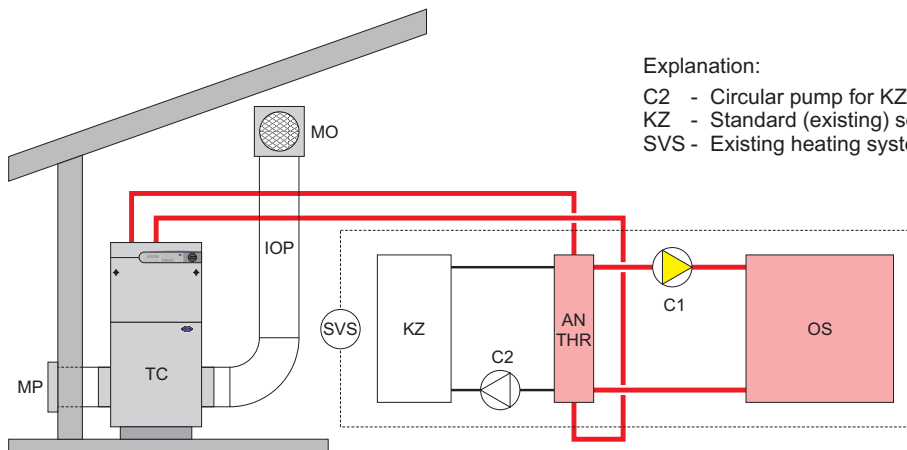

Picture 2 Connection within an existing heating system with an automatically operated, standard heat source such as earth gas boiler, liquid propane, or ecological heating oil.

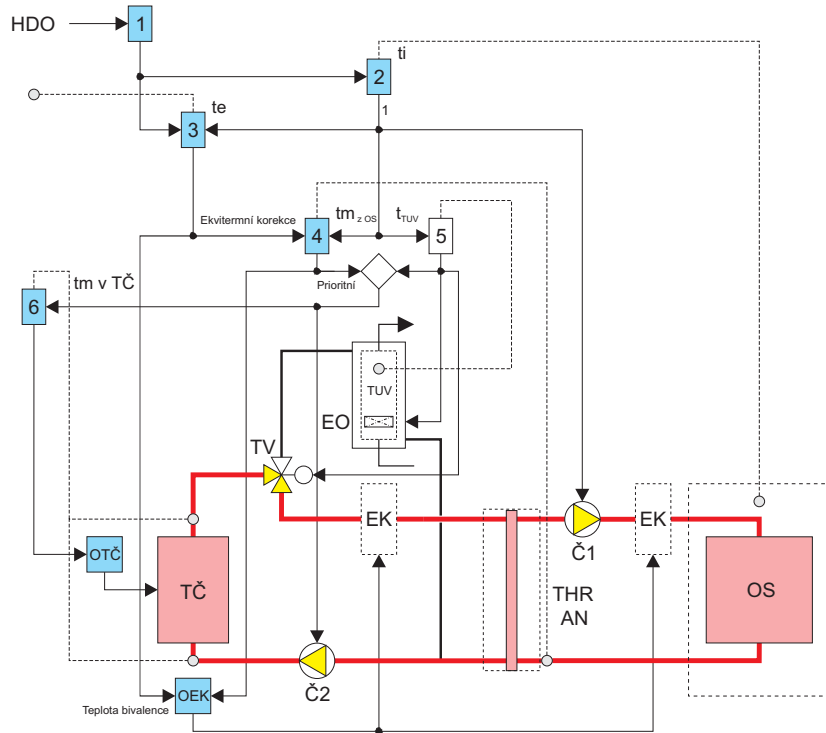

Fig. 9a Example of domestic hot water **warming** (pre- **warming**) during heating system idle condition. Pre-**warming** in a double-jacket heater („Tank in tank“ system) - Heating mode.

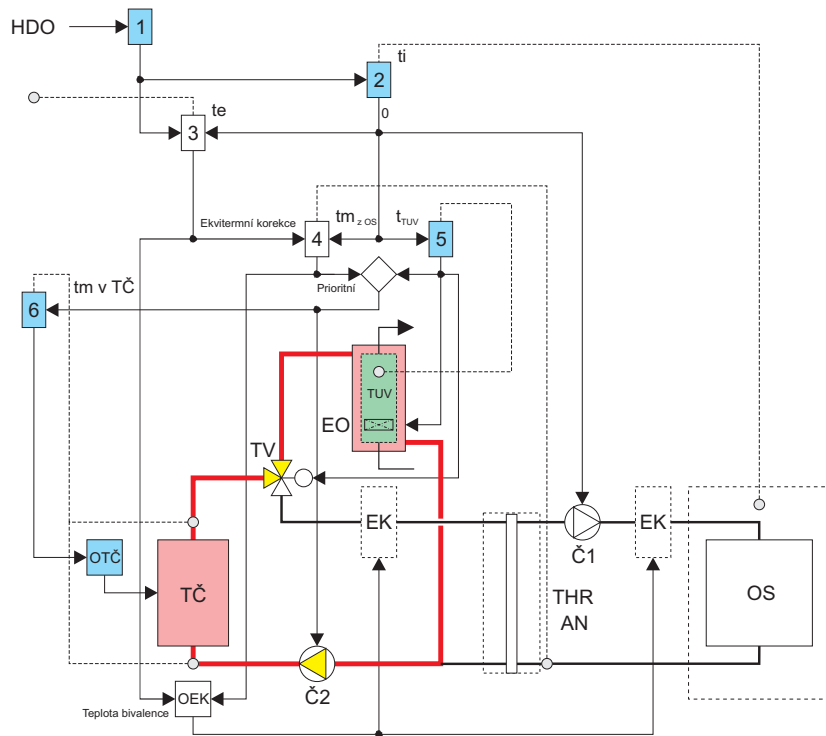

Fig. 9b Example of domestic hot water **warming** (pre- **warming**) during heating system idle condition. Pre-**warming** in a double-jacket heater („Tank in tank“ system) The mode of domestic hot water **warming** (pre- **warming**)